

SP 14 DJ

The robust 16 m telescopic work platform has a telescopic boom with a movable cage arm, a maximum cage load of 270 kg and a maximum lateral outreach of 12.60 m.



Electrical-hydraulic proportional control

Robust and clear basket control



Ground control system

Extensive and easy-to-use ground control.



Movable cage arm

with a cage capacity of up to 270 kg and a large steel basket.

Technical details

Max. Working height	15.90 m	Min. Transportation dimension L x W x H	5.75 x 2.30 x 3.00 m
Max. Lateral range	12.60 m	Max. Transportation dimension L x W x H	7.75 x 2.30 x 2.45 m
Basket rotation angle	+/- 90°	Total weight	8,450 kg
Basket size L x W x H	1.80 x 0.90 x 1.10 m	Max. Height during the procedure	15.90 m
Max. Basket capacity	270 kg	Control system	Electrical-hydraulic proportional control
Rotation angle	360°	Max. Cross slope	+/- 5°
Engine	Yanmar engine (diesel) diesel particulate filter	Max. Gradability	25°

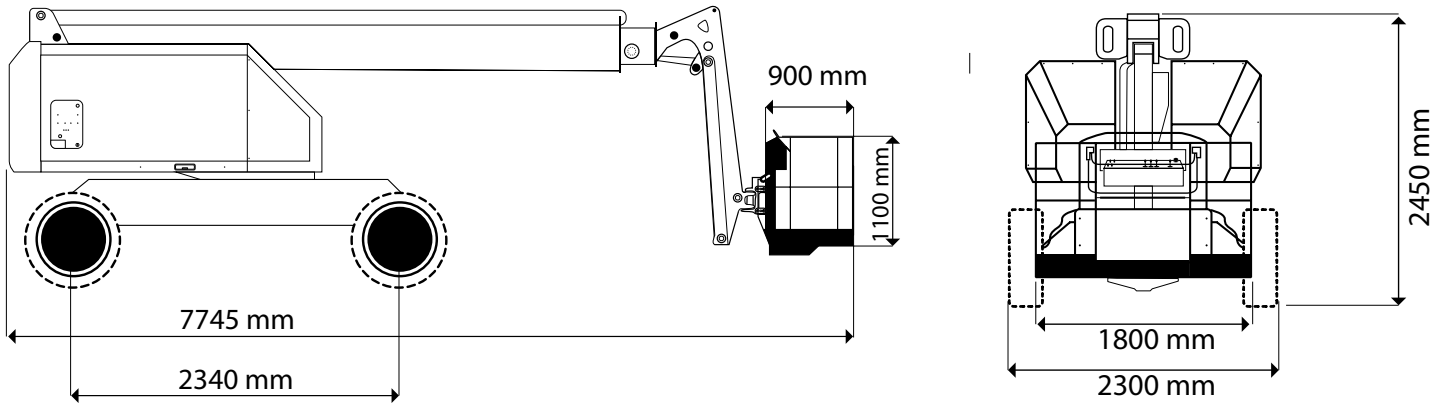

SP 14 DJ Technical details

Max. Working height	15.90 m
Max. Platform height	13.90 m
Max. Lateral range	12.60 m
Overhang from center of rotating tower	2.00 m
Rotation tower angle	360°
Basket rotation angle	+/- 90°
Max. Cage capacity	270.00 kg
basket size L x W x H	1.80 x 0.90 x 1.10 m
Min. Transportation dimension L x W x H	5.75 x 2.30 x 3.00 m
Max. Transportation dimension L x W x H	7.75 x 2.30 x 2.45 m
Total weight	8,450 kg
Max. Height during the procedure	15.90 m
Max. Cross slope	+/- 5°
Max. Gradability	25°
Max. Speed	7.2 km/h / (4.47 mph)
Control system	Electrical-hydraulic proportional control

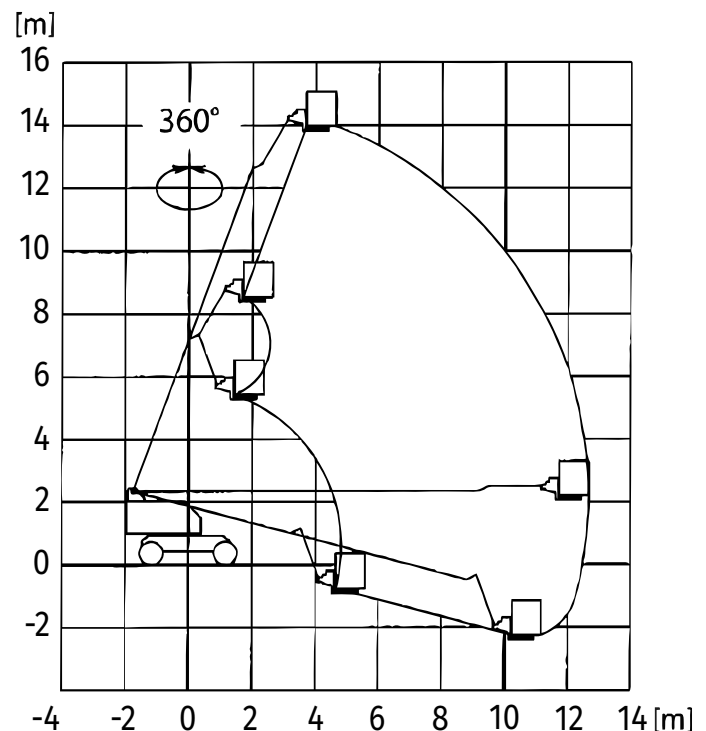

Engine

Engine	Yanmar engine (diesel) 4TNV88-KASV diesel particulate filter
--------	---

Features

<p>Standard features:</p> <ul style="list-style-type: none"> - Movable basket arm - All-terrain tires - 4TNV88-KASV Yanmar engine (diesel) with diesel particulate filter 	<p>Optional extras:</p> <ul style="list-style-type: none"> - 3.5 kW Generator - Customized RAL painting
--	---